

Automatic Paper Carton Erecting Forming Machine



servo motor forming system(option)





Robatech hot melt sytem



plasma system

Technical Specifications

Type	D800	D1200
Production capacity:	40-180 pcs/min	80-320pcs/min
Suitable Material:	200-600gsm card paper, PE coated paper, kraft paper, corrugated paper	
Paper open length:	L100-450mm,degree:5° -40°	
Paper open width:	B100-600mm Height H15-200mm	B100-400mm Height H15-200mm
Total Power:	5KW	6.25KW
Weight:	1.7T	2.4T
Dimension:	3600 x1400 x 1700 mm	3600 x 1850 x 1700 mm
power source	380V 50HZ	

D-model paper carton erecting machine is an ideal choice to produce hamburger boxes, chips boxes, take away box, etc. It adopts micro-computer, PLC, servo feeding, alternating current frequency converter, the vacuum-sucking, auto gluing, automatic paper tape counting, chain drive. All of these main parts and electric control system adopts famous brand to guarantee steady working, precise positioning, smooth running, safety and reliability operation

New Main Features:

- It can make more than 10 types boxes. If the box is not in blow list, please show us your sample.

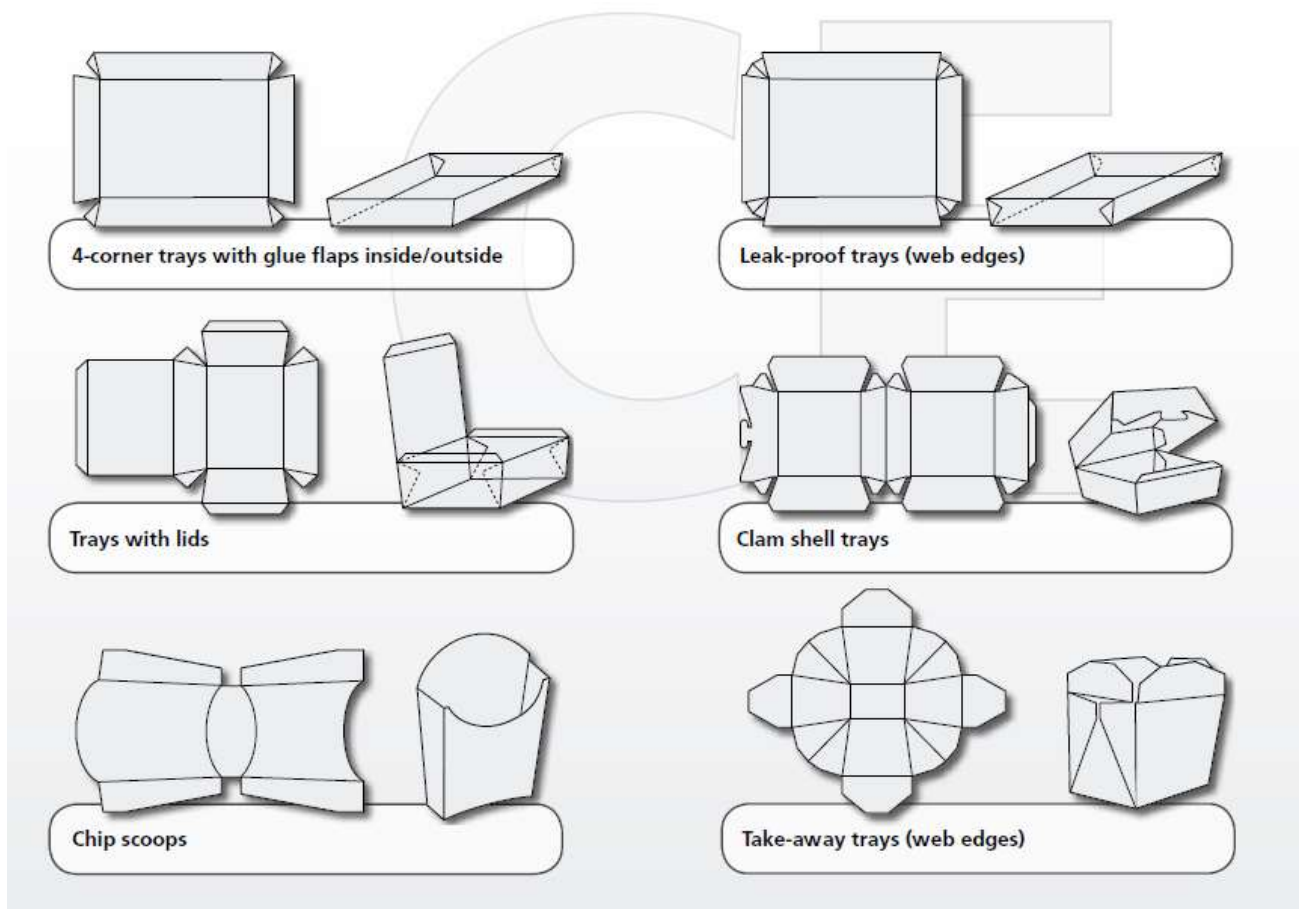

➤ Feeding system: Servo controlled feeding system, Sensor detection system, and Vacuum suction.

1. No need the adjust the distance or change different size cam to control feeding . It save the time and more precision when change the mold.

Volmas Packaging

51 Kaifayi 1st Rd. Ruian, Zhejiang, 325200, China

Phone: +86 186-0666-8229

E-mail: info@volmas.com



2. Sensor detection to control start and stop feeding and more width belt will replace the up down part. Feeding will be much more steady.



➤ Standard electric box and marked clearly.



➤ Chain drive system, and reinforce with metal frame and board.

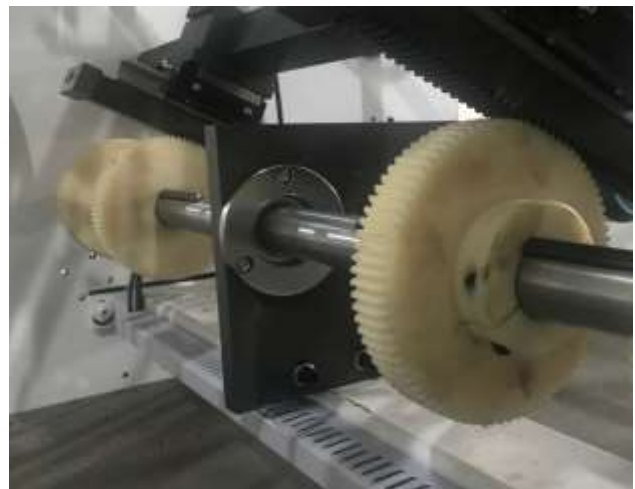

➤ Motor controlled gluing system. Inject glue and change the gluing sponge easily and quickly.



Volmas Packaging

51 Kaifayi 1st Rd. Ruian, Zhejiang, 325200, China

Phone: +86 186-0666-8229

E-mail: info@volmas.com











- The collecting frame can be opened in three parts. It is easier to install the forming spare part and commissioning.



- It adapts the paper tape inserter for counting.



Components Brand:

		D800/1200	
Motor	Main motor	GONNGTAI (CHINA) 	
	Servo motor	INOVANCE 	
	gluing motor	JSCC (TAIWAN) 	
Electric elements	PLC	INOVANCE 	
	HMI	WEINVIEW(TAIWAN) 	
	Frequency converter	INOVANCE 	
	Relay	SCHNEIDER (FRANCE) 	
	Low voltage apparatus	SCHNEIDER (FRANCE) 	
	Bottom	AUTONICS(KOREA) 	
	Close o the switch/photoelectric switch		
Power switch	MEAN WELL (TAIWAN)		

Volmas Packaging

51 Kaifayi 1st Rd. Ruian, Zhejiang, 325200, China

Phone: +86 186-0666-8229

E-mail: info@volmas.com

		The logo for Mean Well, consisting of the letters 'MW' in a red box with 'MEAN WELL' and Chinese characters '明纬' below it.	
Pneumatic	Main air cylinder	AIRTAC(TAIWAN) The logo for AirTAC, with the word 'AirTAC' in a blue, stylized font.	
Belt	paper feeding belt	TIGER(ITALY)	
	convey belt		
Bearing	Main Bearing	HRB/BEM	