

FD-330 Adjustable Roll Feeding Square Bottom Paper Bag Machine



SAMPLE PICTURE



Properties and uses :

Machine use roller paper, from primary color paper or printed web paper to square bottom paper bag one times production. The machine can be used in various paper bags with high speed and efficiency. It is an ideal equipment for paper bag production.

This machine is composed of roll unwinding (hydraulic feeding, automatic web guide, constant tension), side gluing, printing electric eye tracking, base paper into cylinder, fixed-length traction cutting, bag bottom indentation opening, bag bottom gluing, bag bottom molding, bag sending etc. The whole machine is controlled centrally by PLC touch screen and servo motor controls the length of paper bag.

It can pretend 2 color /4 color printing group, bag surface window lamination device and handgrip hole device according to your need.

Can be matched with rope twisting, flat rope handlebar machine, rewinding machine, etc., to make the products more competitive and diversified.

Technical parameter

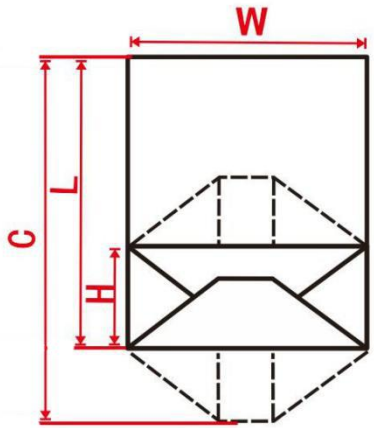
Model	FD-330	
Paper Roll Length	270-530mm (C)	
Paper bag length	225-470mm (L)	
Paper bag width	150-330mm (W)	
Paper bag bottom width	60-160mm (H)	
Paper thickness	60-160g/m2	
Max Bag Making Speed	30-160pcs/min	
Roll paper width	450-1050mm	
Paper roll diameter	1200mm	
Diameter of paper core	76mm (3")	
Machine power	3phase,380v ,12kw	
Machine weight	8000kg	
Machine size	10500x3700x1900mm	

1. Use Taiwan Weinview Touch Screen Human-Computer Interface, operate and control easily.
2. Adopt Japan Original Mitsubishi PC Control, integrated with optical fiber, ensure high-speed running steadily.
3. Japan Original Mitsubishi Servo Motor and Germany Original SICK Photoelectric Eye Correction, tracking printing bag accurately.
4. Raw material loading and unloading adopts motor lifting structure, and unwinding adopts automatic constant tension control
5. Material correction from Germany BEDOOK

Electrical Components List

Name	Qty	Original	Brand
Control System			
PLC SPOT Control	1	Japan	Mitsubishi
Touch Screen	1	Taiwan	Weinview
Servo Motor	2	Japan	Mitsubishi
Servo Drive	2	Japan	Mitsubishi
Counting Servo Motor	1	Japan	Mitsubishi
Counting Servo Driver	1	Japan	Mitsubishi
Bag Forming Inverter	1	Japan	Mitsubishi
Printing Tracking Electric Eye	1	German	SICK
Low Voltage Electrical Appliances	1	French	SCHNEIDER
Pneumatic components	1	Taiwan	AirTAC
Automatic Lubricator	1	China	

Web/Tension Control System			
Web Guide Control System	1	German	BEDOOK
Unwinding Paper Roll Air shaft	1	China	
Magnetic Powder Brake	1	China	WEIZHENG
Drive			
Synchronous Belt	1/set	China	BELDI
Synchronous Pulley	1/set	China	HW
Bear	1/set	China	LYC
Guide Roll	1/set	China	BAIXIAO
Gear	1/set	China	HW
Glue Part			
Bottom Glue Equably Motor	1	China	
Pneumatic Ink Separator Pump	1	China	
Middle/ Edge Water Rubber Gun	1	China	
Water Glue Pressure Bucket	1	China	HW

Note: The purchased parts used in this machine will be replaced by a brand of the same quality not less than the existing brand when the equipment is upgraded or updated. The Seller reserves the right without further notice.

Machine packaging dimensions

Name	Overall dimension (With the cases)	Gross Weight
MAIN MACHINE	4000*1800*1800mm	6000kg
Roll feeding part	1700*2100*1780mm	1100kg
discharging unit	2900*950*1260mm	650kg
Electric box	1100*500*1850mm	150kg
Foot steps	2330*700*700mm	200kg